

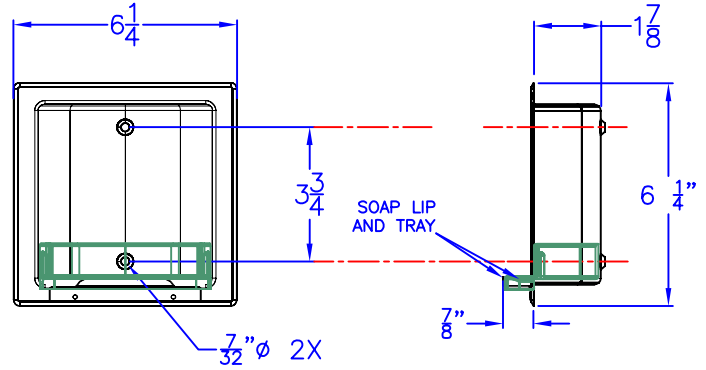

# Technical Data

## S-2612-XX

### RECESSED SOAP DISH WITH LIP & TRAY

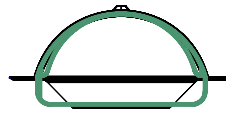

DRY WALL CLAMP  
S-2609-01

MOUNTING SYSTEMS

TILE TYPE LUGS  
S-2601-01

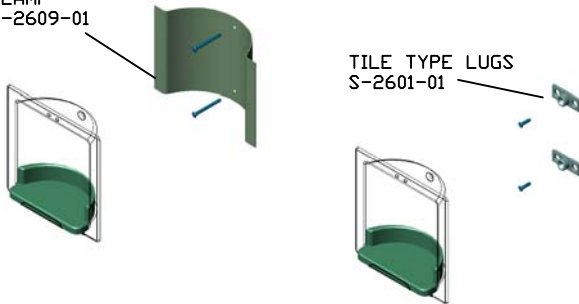

OPTIONAL MOUNTING SYSTEMS COME WITH APPROPRIATE SCREWS.

FINISH CODE: -XX

-SS = SATIN

-BS = BRIGHT

-PC = POWDER COATED (SPECIFY COLOR)

### Construction:

SHELL: 22 GAUGE TYPE 304 STAINLESS STEEL FORMED ONE PIECE WITH BEVELED EDGES. (2) 7 / 32" Ø MTG. HOLES CTSK. FOR A #10 OVAL HEAD SCREW.  
 SOAP LIP: 22 GAUGE TYPE 304 STAINLESS STEEL FORMED ONE PIECE. FASTEN TO SHELL.  
 SOAP TRAY: MOLDED ONE PIECE CLEAR PLASTIC.  
 SCREWS: COMES WITH (2) #10 X 1" OVAL PHILIPS STAINLESS STEEL SMS.

### Operation:

SOAP DISH WITH SOAP LIP AND TRAY

### Installation:

ROUGH WALL OPENING OF 5 1/4" X 5 1/4" X 2" DEEP REQUIRED.  
 USE SHELL TO MARK LOCATION.  
 CUT OPENING THROUGH WALL.  
 FASTEN TO WALL USING SCREWS PROVIDED OR OPTIONAL MOUNTING SYSTEMS SHOWN ABOVE.

CAUTION: RECESSED SHELL REQUIRES NO OBSTRUCTIONS BEHIND WALL. UNIT IS ONLY AS STRONG AS THE ANCHORING DEVICES AND THE WALL ON WHICH IT IS MOUNTED TO.

### Guide Specification:

FABRICATED FROM TYPE 304 STAINLESS STEEL IN FINISHES REQ. (AS LISTED ABOVE)  
 RECESSED SOAP DISH WITH SOAP LIP AND CLEAR PLASTIC TRAY.  
 ROUGH WALL OPENING REQUIRED IS 5 1/4" X 5 1/4" X 2" DEEP.

The manufacturer reserves the right to make changes in design and material without formal notice and without incurring obligation

© Copyright 2005  
 Brey-Krause Manufacturing

Brey-Krause Manufacturing  
 1209 West Lehigh Street, Bethlehem, PA 18018  
 Phone: 610.867.1401 Fax: 610.866.1433  
 www.breykrause.com